

DO NOT SCALE. IF IN DOUBT ASK!

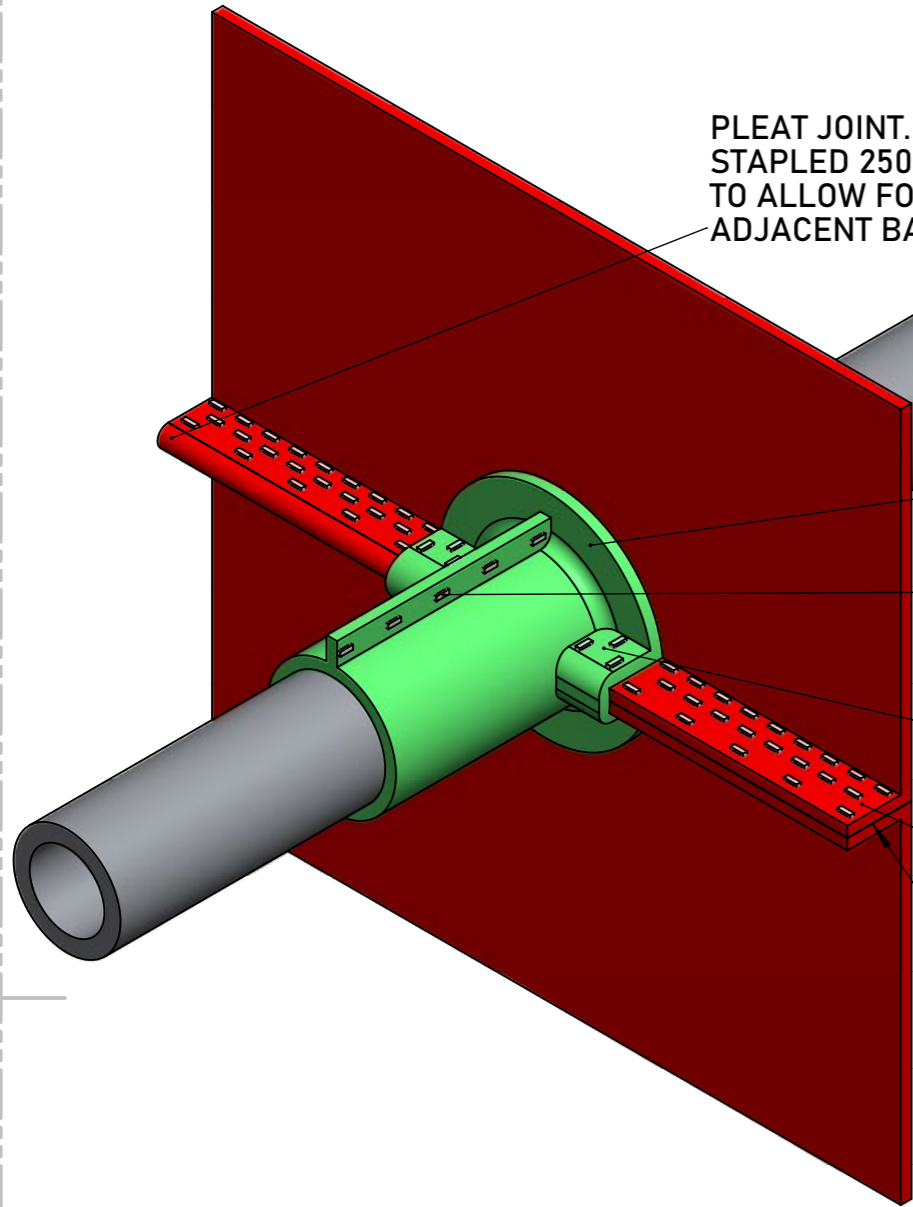

PLEAT JOINT.
STAPLED 250mm UPTO THE END OF BARRIER,
TO ALLOW FORMATION OF VERTICAL JOINT TO
ADJACENT BARRIER.

METALLIC PENETRATION.

FLANGE SECURED FLUSH TO BARRIER WITH 2 BEADS
OF FIREFLY™ HIGH TEMPERATURE ADHESIVE.

FIREFLY™ COLLAROLL TO BE STAPLED TO
ITSELF USING 12mm STAPLES AT 80mm
CENTRES.

FIREFLY™ COLLAROLL WRAPPED AROUND
AND SEALED TO JOINT WITH HTA AND 12mm
STAPLES AS REQUIRED.

BUTT JOINT.
STAPLED 250mm UPTO THE END OF BARRIER,
TO ALLOW FORMATION OF VERTICAL JOINT TO
ADJACENT BARRIER.

SEAL END OF JOINT WITH FIREFLY™
HIGH TEMPERATURE ADHESIVE.

THE COLLAROLL SHOULD BE FIT AS TIGHTLY
AS POSSIBLE AROUND THE PENETRATION.

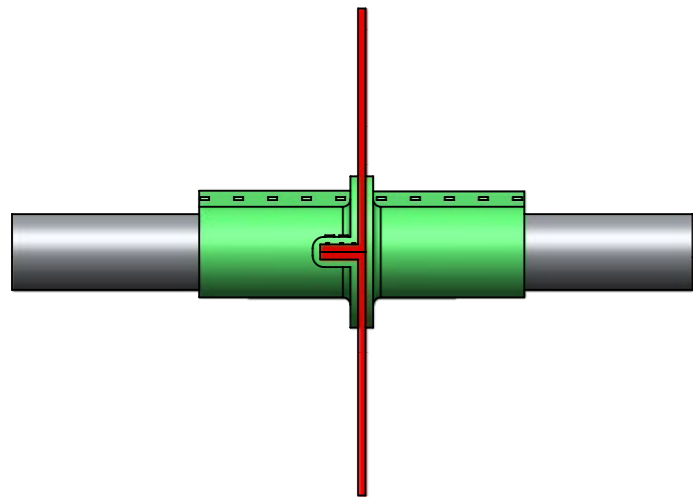

2 ROWS OF 12mm STAPLES STAGGERED AT 50mm CENTRES,
CLOSING STAPLES AT 150mm CENTRES.

PLEAT JOINT DETAILS.

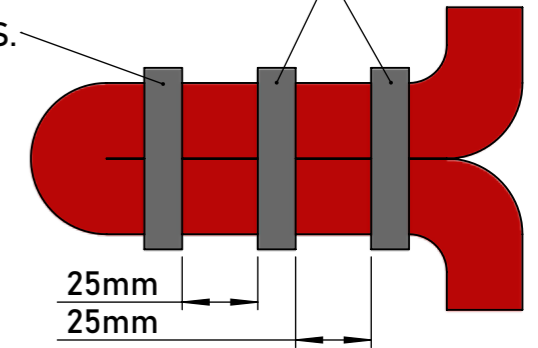

PENETRATION DETAILS.

LOCATION OF PENETRATION.

CUT A SLOT AND FEATHER
PENETRATION INTO THE
FIREFLY™ BARRIER 50mm
BELOW THE CENTRE LINE
OF THE PENETRATION.

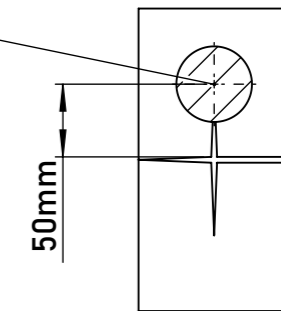

2 ROWS OF 12mm STAPLES STAGGERED AT 50mm CENTRES,
CLOSING STAPLES AT 150mm CENTRES.

BUTT JOINT DETAILS.

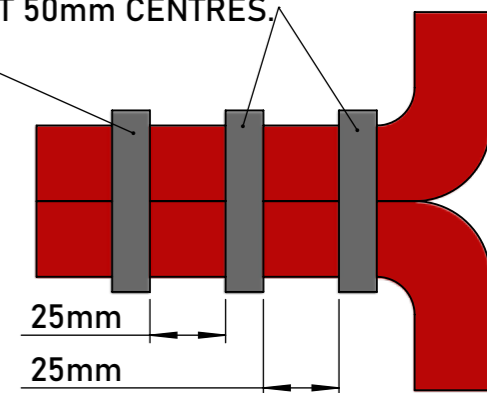

APOLLO LITE™ - PLEAT JOINT FOR PENETRATION

TBA PROTECTIVE TECHNOLOGIES LTD

UNIT 3, Transpennine Trading Estate, Gorrells Way
Rochdale, OL11 2PX, United Kingdom

T: +44 (0)1706 758 817
E: Technical@TBAFIREFLY.com
W: www.tbafirefly.com

ARTIST: JC

APPROVED: DA

DATE: 07/12/2022

SCALE: NTS

DRAWING NO:

A - 008B

REVISION: 1

IN SEQUENCE: 1/1

ALL RIGHTS RESERVED. NO PARTS OF THIS DRAWING MAY BE USED REPRODUCED, ALTERED, STORED IN A RETRIEVAL SYSTEM OR TRANSMITTED IN ANY FORM OR BY ANY MEANS WITHOUT THE PRIOR WRITTEN PERMISSION OF TBA PROTECTIVE TECHNOLOGIES LTD. WHILST EVERY EFFORT HAS BEEN MADE TO COMPLY WITH THE CURRENT STATUTORY REGULATIONS, IT IS THE USER'S RESPONSIBILITY TO ENSURE THAT THE FINAL DETAILING AND INSTALLATION MEETS THE REQUIREMENTS OF RELEVANT REGULATORY AUTHORITY (OFTEN BUILDING CONTROL). PLEASE CHECK www.tbafirefly.com TO ENSURE THAT YOU ARE USING THE CORRECT AND CURRENT VERSION. COPYRIGHT 2022

