

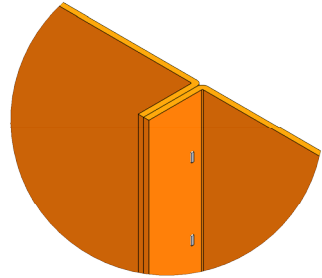

DO NOT SCALE. IF IN DOUBT ASK!

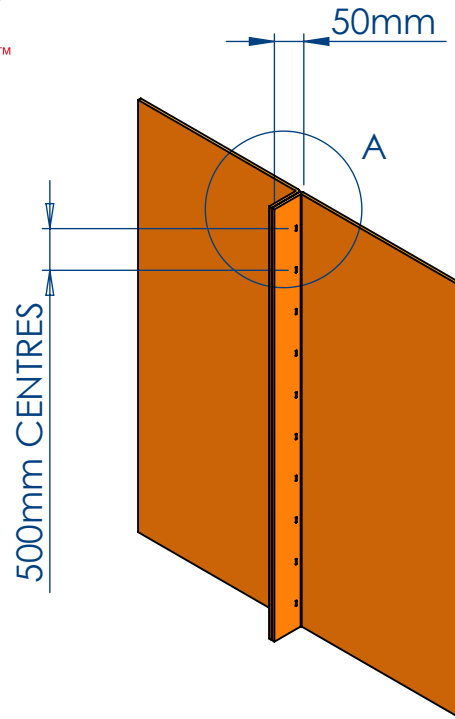

DETAIL A



**JOINT CONSTRUCTION - STEP 1**

BRING THE TWO FIREFLY™ SHEETS TOGETHER ENSURING THAT THERE IS A MINIMUM 50mm TAIL. FORM THE JOINT AND STAPLE AT 500mm CENTRES USING 8mm STAPLES.

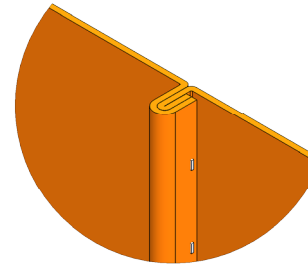

DETAIL B

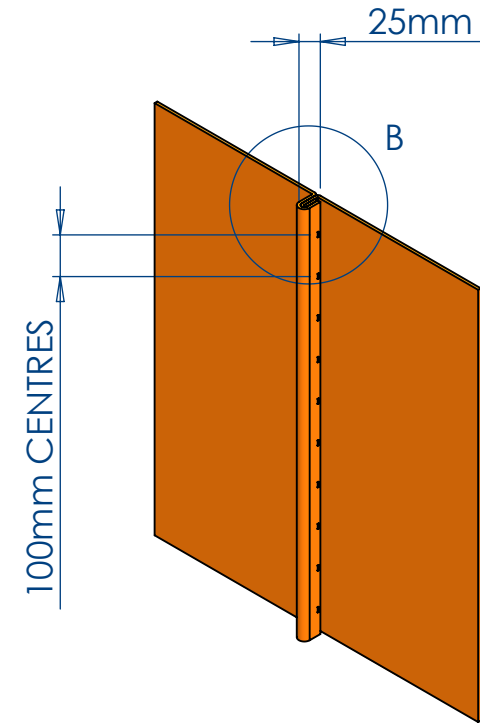

**JOINT CONSTRUCTION - STEP 2**

FOLD THE 50mm FORMED SEAM BACK ON ITSELF TO PRODUCE A 25mm CONTINUOUS SEAL JOINT. FIX WITH 8mm STAPLES AT 100mm MAXIMUM CENTRES.

ALL RIGHTS RESERVED. NO PART OF THIS DRAWING MAY BE USED, REPRODUCED, ALTERED, STORED IN A RETRIEVAL SYSTEM OR TRANSMITTED IN ANY FORM OR BY ANY MEANS WITHOUT THE PRIOR WRITTEN PERMISSION OF TBA PROTECTIVE TECHNOLOGIES LTD. WHILST EVERY EFFORT HAS BEEN MADE TO COMPLY WITH THE CURRENT STATUTORY REGULATIONS, IT IS THE USER'S RESPONSIBILITY TO ENSURE THAT THE FINAL DETAILING AND INSTALLATION MEETS THE REQUIREMENTS OF RELEVANT REGULATORY AUTHORITY (OFTEN BUILDING CONTROL). PLEASE CHECK [www.tbafirefly.com](http://www.tbafirefly.com) TO ENSURE THAT YOU ARE USING THE CORRECT AND CURRENT VERSION. COPYRIGHT 2019

TBA Protective Technologies Ltd  
Unit 3, Transpennine Trading Estate  
Gorrells Way, Rochdale, OL11 2PX  
United Kingdom  
T: +44 (0)1706 758 817  
E: [technical@tbafirefly.com](mailto:technical@tbafirefly.com)  
W: [www.tbafirefly.com](http://www.tbafirefly.com)



Drawn By: RJ

Approved By: MPR

Scale: NTS

Date: 25/06/2020

Title: FIREFLY™ PHOENIX  
DOUBLE FOLD  
VERTICAL JOINT

Drawing No.

P/006

Rev:

1