

DO NOT SCALE. IF IN DOUBT ASK!

JOINT DETAILS.

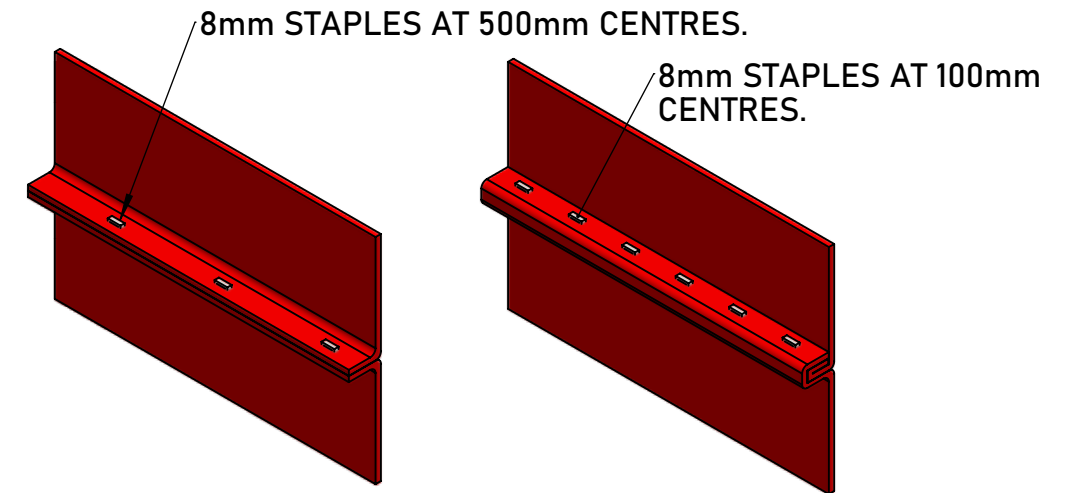

THE BARRIERS ARE BROUGHT TOGETHER AND FIXED FIRST WITH 8mm STAPLES AT 500mm CENTRES BEFORE BEING FOLDED OVER AND FIXED WITH 8mm STAPLES AT 100mm CENTRES.

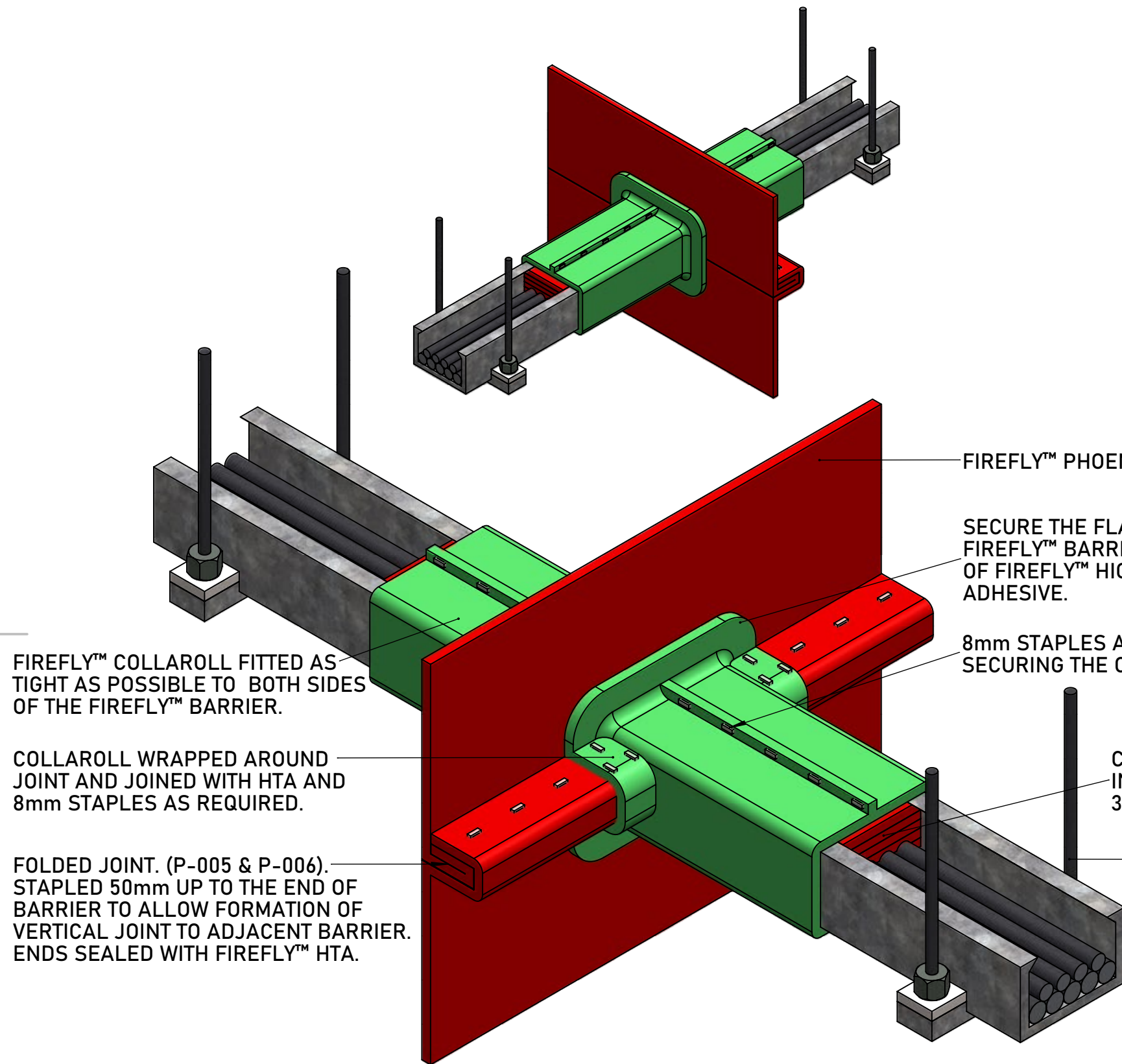

FIREFLY™ COLLAROLL FITTED AS TIGHT AS POSSIBLE TO BOTH SIDES OF THE FIREFLY™ BARRIER.

COLLAROLL WRAPPED AROUND JOINT AND JOINED WITH HTA AND 8mm STAPLES AS REQUIRED.

FOLDED JOINT. (P-005 & P-006). STAPLED 50mm UP TO THE END OF BARRIER TO ALLOW FORMATION OF VERTICAL JOINT TO ADJACENT BARRIER. ENDS SEALED WITH FIREFLY™ HTA.

FIREFLY™ PHOENIX™ BARRIER.

SECURE THE FLANGE FLUSH TO THE FIREFLY™ BARRIER USING 2 BEADS OF FIREFLY™ HIGH TEMPERATURE ADHESIVE.

8mm STAPLES AT 80mm CENTRES, SECURING THE COLLAROLL TO ITSELF.

CABLE TRAY PACKED TO BE PACKED OUT WITH AN INSULATING FIREFLY™ BARRIER AS REQUIRED. 300mm FROM EITHER SIDE OF THE BARRIER.

CABLE TRAY SUPPORTS, INSTALLED PER MANUFACTURER INSTRUCTIONS.

PHOENIX™ - CABLE TRAY PENETRATION

TBA PROTECTIVE TECHNOLOGIES LTD

UNIT 3, Transpennine Trading Estate, Gorrells Way
Rochdale, OL11 2PX, United Kingdom

T: +44 (0)1706 758 817
E: Technical@TBAFIREFLY.com
W: www.tbafirefly.com

ARTIST: JC

APPROVED: DA

DATE: 07/12/2022

SCALE: NTS

DRAWING NO:

P - 232

REVISION: 1

IN SEQUENCE: 1/1

ALL RIGHTS RESERVED. NO PARTS OF THIS DRAWING MAY BE USED REPRODUCED, ALTERED, STORED IN A RETRIEVAL SYSTEM OR TRANSMITTED IN ANY FORM OR BY ANY MEANS WITHOUT THE PRIOR WRITTEN PERMISSION OF TBA PROTECTIVE TECHNOLOGIES LTD. WHILST EVERY EFFORT HAS BEEN MADE TO COMPLY WITH THE CURRENT STATUTORY REGULATIONS, IT IS THE USER'S RESPONSIBILITY TO ENSURE THAT THE FINAL DETAILING AND INSTALLATION MEETS THE REQUIREMENTS OF RELEVANT REGULATORY AUTHORITY (OFTEN BUILDING CONTROL). PLEASE CHECK www.tbafirefly.com TO ENSURE THAT YOU ARE USING THE CORRECT AND CURRENT VERSION. COPYRIGHT 2022

