

DO NOT SCALE. IF IN DOUBT ASK!

41 x 41 mm UNISTRUT CHANNEL.

UNISTRUT WRAPPED IN FIREFLY™ BARRIER.

ALLOW APPROX 6mm EXTRA GAP TO ALLOW FOR BATT AND MASTIC.

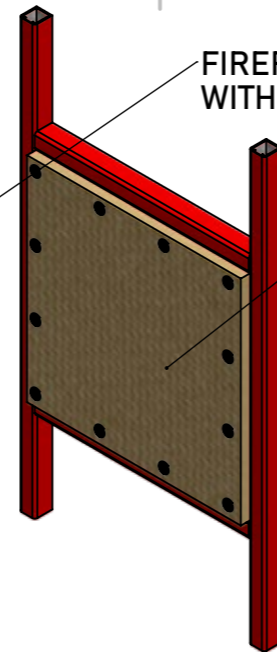
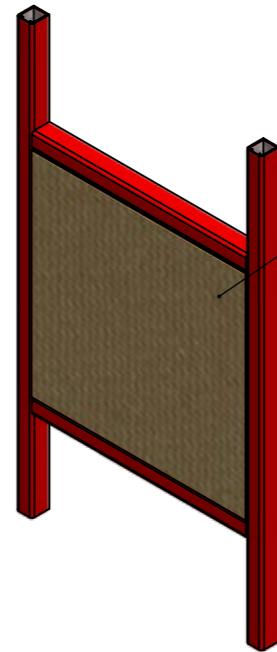
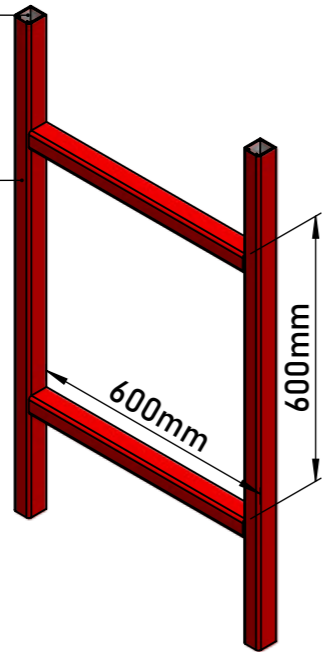

FIREFLY™ FB 180 BATT, CUT TO SIZE BEFORE BEING BUTTERED WITH ACRYLIC INTUMESCENT MASTIC AND FRICTION FIT INTO THE FRAMEWORK.

A SECOND LAYER OF FIREFLY™ FB 180 BATT IS APPLIED TO THE FIRST AND FIXED TO ITSELF WITH GALVANISED PIGTAIL SCREWS AT 200mm MIN. PIGTAIL SCREWS SHOULD BE 50mm AWAY FROM EDGE OF BATT.

GALVANISED PIGTAIL SCREWS SECURING THE BATTS TOGETHER AT 200mm CENTRES. PIGTAIL SCREWS SHOULD BE 50mm AWAY FROM EDGE OF BATT.

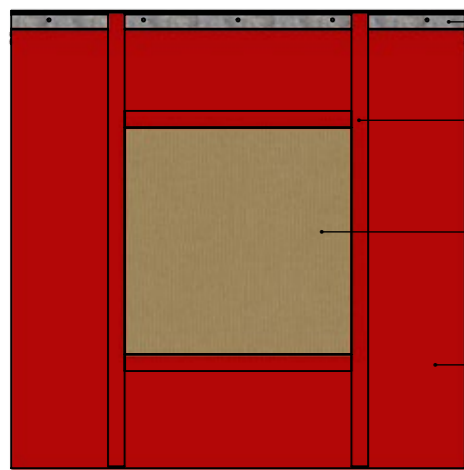

TOP FIX (P-002).

WRAPPED UNISTRUT FRAMEWORK.

2 LAYERS OF FIREFLY™ FB 180 BATT.

FIREFLY™ PHOENIX™ BARRIER.

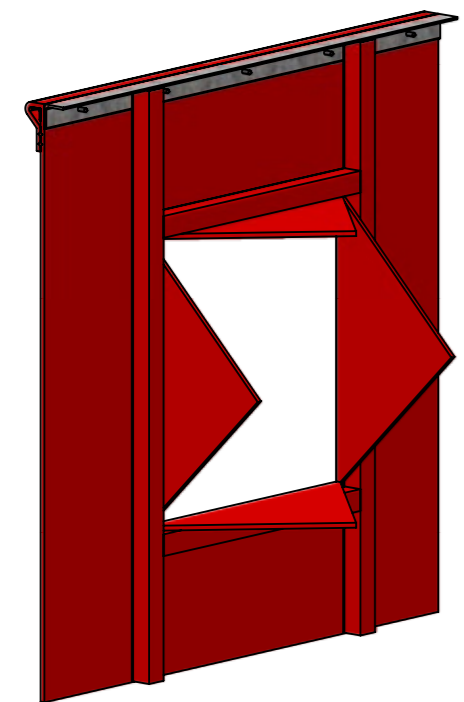

THE FRAMEWORK IS INSTALLED AND WRAPPED FIRST.

THE TOP FIX AND VERTICAL BARRIER IS INSTALLED SECOND.

CUT THE BARRIER AS REQUIRED TO ACCOMMODATE THE PENETRATION.

THE EXCESS BARRIER FROM THE CUT CAN BE WRAPPED AROUND THE FRAMEWORK.

THEN THE BATT SHOULD BE BUTTERED WITH INTUMESCENT ACRYLIC MASTIC BEFORE BEING FRICTION FITTED INTO THE FRAMEWORK.

A SECOND LAYER OF BATT IS PLACED OVER THE FIRST AND FIXED IN PLACE WITH GALVANISED PIGTAILS SCREWS AT 200mm CENTRES.

FINALLY THE BATT IS PAINTED WITH BRUSH GRADE INTUMESCENT MASTIC AFTER INSTALL.

TOP FIX (P-002).

FIREFLY™ PHOENIX™ BARRIER.

2 LAYERS OF FIREFLY™ FB 180 BATT.

BATT PAINTED WITH BRUSH GRADE INTUMESCENT MASTIC AFTER INSTALL.

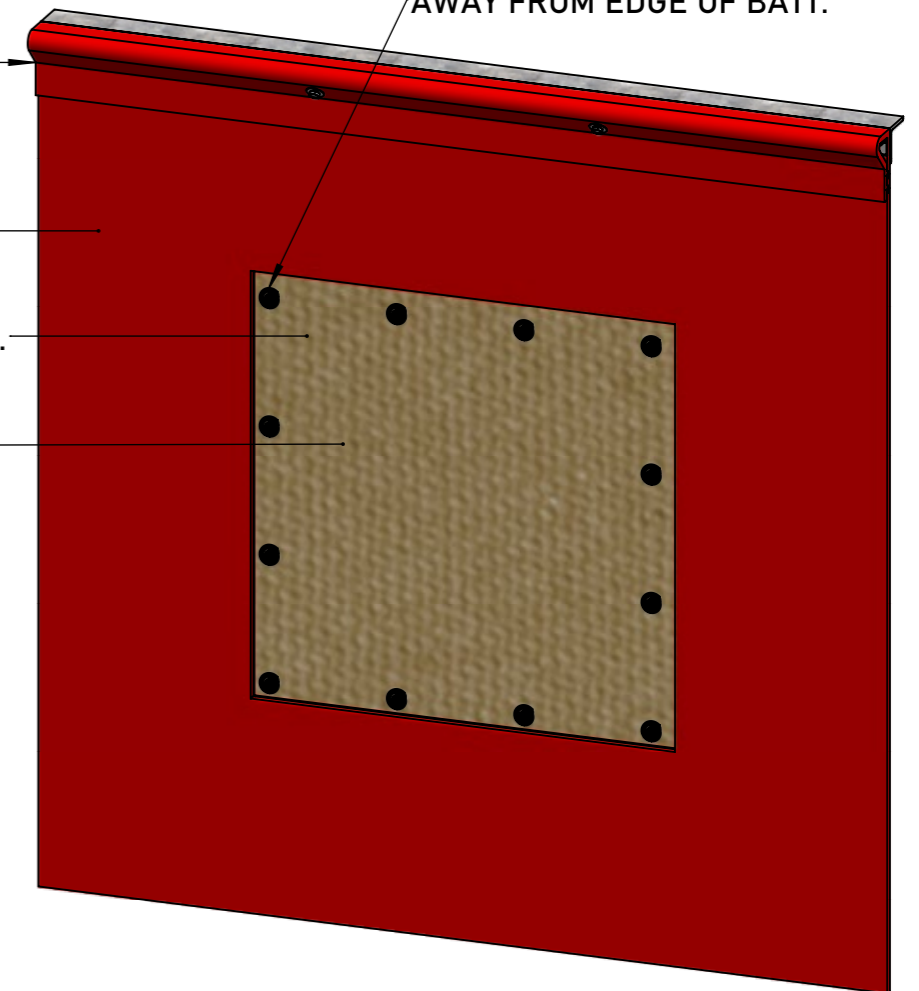

PHOENIX™ - DOUBLE BATT INTO FRAMEWORK

TBA PROTECTIVE TECHNOLOGIES LTD

UNIT 3, Transpennine Trading Estate, Gorrells Way
Rochdale, OL11 2PX, United Kingdom

T: +44 (0)1706 758 817
E: Technical@TBAFIREFLY.com
W: www.tbafirefly.com

ARTIST: JC

APPROVED: DA

DATE: 07/12/2022

SCALE: NTS

DRAWING NO:

P - 408

REVISION: 1

IN SEQUENCE: 1/1

ALL RIGHTS RESERVED. NO PARTS OF THIS DRAWING MAY BE USED REPRODUCED, ALTERED, STORED IN A RETRIEVAL SYSTEM OR TRANSMITTED IN ANY FORM OR BY ANY MEANS WITHOUT THE PRIOR WRITTEN PERMISSION OF TBA PROTECTIVE TECHNOLOGIES LTD. WHILST EVERY EFFORT HAS BEEN MADE TO COMPLY WITH THE CURRENT STATUTORY REGULATIONS, IT IS THE USER'S RESPONSIBILITY TO ENSURE THAT THE FINAL DETAILING AND INSTALLATION MEETS THE REQUIREMENTS OF RELEVANT REGULATORY AUTHORITY (OFTEN BUILDING CONTROL). PLEASE CHECK www.tbafirefly.com TO ENSURE THAT YOU ARE USING THE CORRECT AND CURRENT VERSION. COPYRIGHT 2022

